



Follow the Leader™



## INTRODUCING Aluminum Enclosed Pan Cabinet

### Features:

- 14 Ga., Aluminum Heavy Duty Welded Construction
- Enclosed Extrusions
- 5" Poly Plate Casters, 2 With Brakes
- Low-Profile Door Latch
- 37 Pan Capacity
- Optional Bumpers Available
- Optional Pull Handle For Improved Mobility. Does not Interfere With Other Side By Side Units.
- Fully welded cabinet maximum strength and durability.
- Door swing full 270 degrees.
- Casters positioned within outer perimeter to avoid interference
- 6063 extruded aluminum slides and uprights.
- Heavy gauge aluminum top and bottom panels.
- Heavy gauge aluminum door.



MODEL	Description	Pan Capacity	Shelf Spacing	Overall Size L x W x H	Weight
EPC-40	Front Load	37 Full Size Pans	1-1/2"	20 1/2" x 27-1/2" x 66 1/4"	110 lbs.



Follow the Leader™

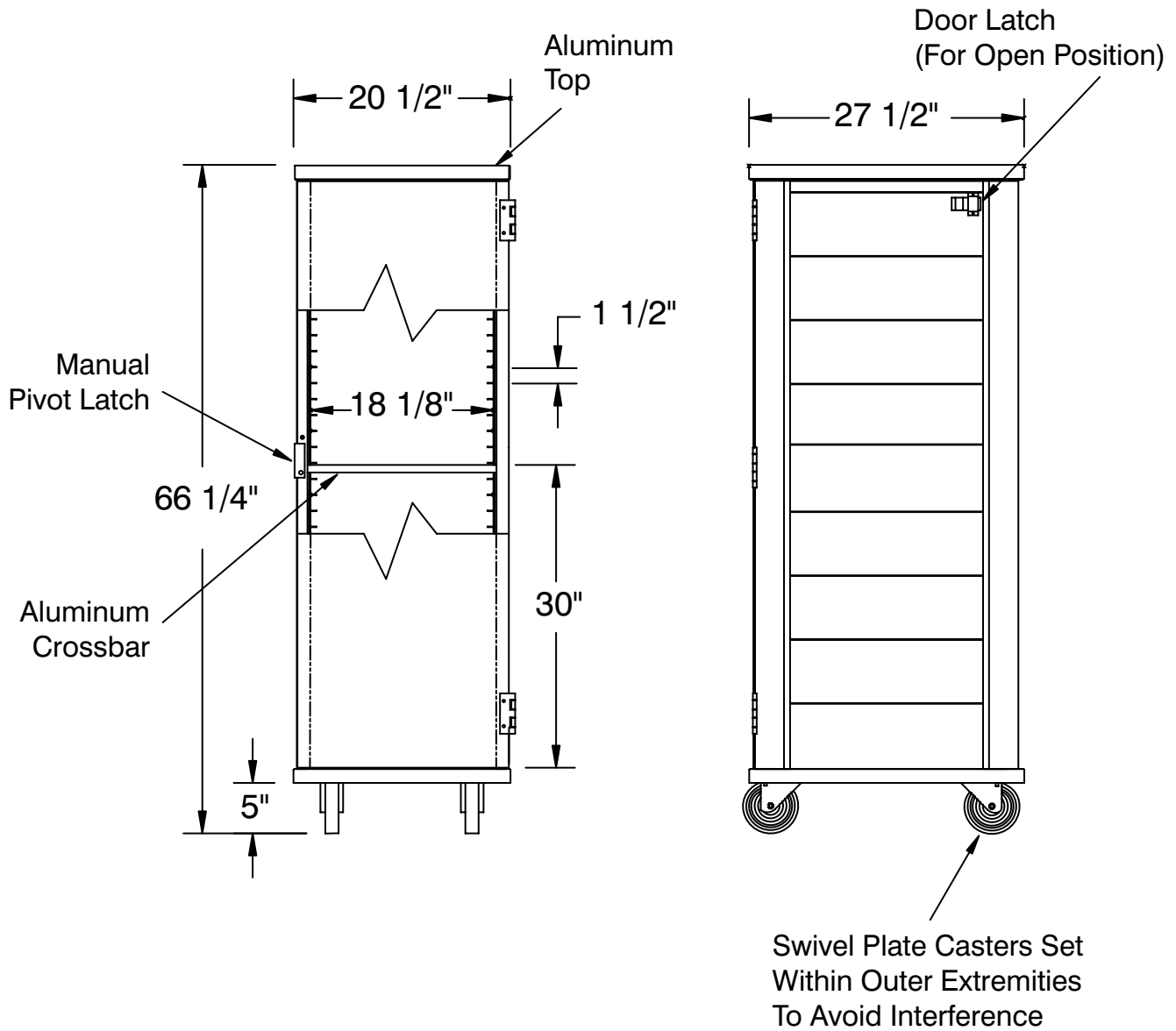

Direct Phone & Service: (516) 527-3309 • (888) 443-7014 • [info@unisourcefoodequipment.com](mailto:info@unisourcefoodequipment.com) • [unisourcefoodequipment.com](http://unisourcefoodequipment.com)  
170 Wilbur Place, Suite 300, Bohemia, New York, 11716

UNISOURCE is constantly engaged in a program of improving our products. Therefore, we reserve the right to change specifications without prior notice.  
Not responsible for typographical errors. © Unisource Food Equipment Systems, Inc. JUNE 2020