



Mixer Tables

AG-MT-242
Shown



MT-SS-242
Shown



MX-SS-242
Shown
(Mixer not included)



Features:

- TOP is furnished with a 2" x 1" square die embossed NO-DRIP countertop offset edge with a 1/2" return on 4 sides.
- Aluminum die cast "leg-to-shelf" clamp secures shelf to leg eliminating unsightly nuts and bolts. Undershef is adjustable.
- Entire Top is polished to a satin finish and is sound deadened. Countertop edge polished to a MIRROR FINISH.

MX-SS & MT-SS SERIES - Stainless Steel Base

TOP is 14 gauge stainless steel type "304" series with galvanized understructure.

UNDERSHELF is 18 gauge stainless steel.

LEGS are 1 5/8" diameter tubular stainless steel with stainless steel bullet feet & gussets.

UTENSIL RACK on MX-SS Series is 1 5/8" dia. stainless steel tubing with stainless steel hooks.

MX-GL & MT-GL Series - Galvanized Steel Base

TOP is 14 gauge stainless steel type "304" series with galvanized understructure.

UNDERSHELF is galvanized steel.

LEGS are 1 5/8" diameter, tubular galvanized steel. Gussets are galvanized steel with 1" adjustable plastic bullet feet.

UTENSIL RACK on MX-GL Series is 1 5/8" diameter galvanized steel tubing with stainless steel hooks.

SAG-MT & AG-MT Budget Series

TOP is heavy gauge stainless steel type "430" series with galvanized understructure.

SAG-MT Series UNDERSHELF is 18 gauge stainless steel.

AG-MT Series UNDERSHELF is galvanized steel.

SAG-MT Series LEGS are 1 5/8" diameter, tubular stainless steel with 1" adjustable stainless steel bullet feet.

AG-MT Series LEGS are 1 5/8" diameter, tubular galvanized steel with 1" adjustable plastic bullet feet.

UTENSIL RACK & UNDERSHELF

O.A. Size W x L	Stainless Steel Base	Galvanized Base	Approx. Wt.	Approx. Cu. Ft.
24" x 24"	MX-SS-242	MX-GL-242	53 lbs.	3
30" x 24"	MX-SS-302	MX-GL-302	63 lbs.	3
30" x 30"	MX-SS-300	MX-GL-300	70 lbs.	4
30" x 36"	MX-SS-303	MX-GL-303	77 lbs.	4
36" x 36"	MX-SS-363	MX-GL-363	81 lbs.	5

WITH UNDERSHELF

O.A. Size W x L	Stainless Steel Base	Galvanized Base	Approx. Wt.	Approx. Cu. Ft.
24" x 24"	MT-SS-242	MT-GL-242	45 lbs.	3
30" x 24"	MT-SS-302	MT-GL-302	50 lbs.	3
30" x 30"	MT-SS-300	MT-GL-300	55 lbs.	4
30" x 36"	MT-SS-303	MT-GL-303	68 lbs.	4
36" x 36"	MT-SS-363	MT-GL-363	71 lbs.	5

BUDGET SERIES WITH UNDERSHELF

O.A. Size W x L	Stainless Steel Base	Galvanized Base	Approx. Wt.	Approx. Cu. Ft.
24" x 24"	SAG-MT-242	AG-MT-242	38 lbs.	3
30" x 24"	SAG-MT-302	AG-MT-302	41 lbs.	3
30" x 30"	SAG-MT-300	AG-MT-300	52 lbs.	4
30" x 36"	SAG-MT-303	AG-MT-303	58 lbs.	4
36" x 36"	SAG-MT-363	AG-MT-363	64 lbs.	5

Mixer Tables

MT, SAG & AG Series

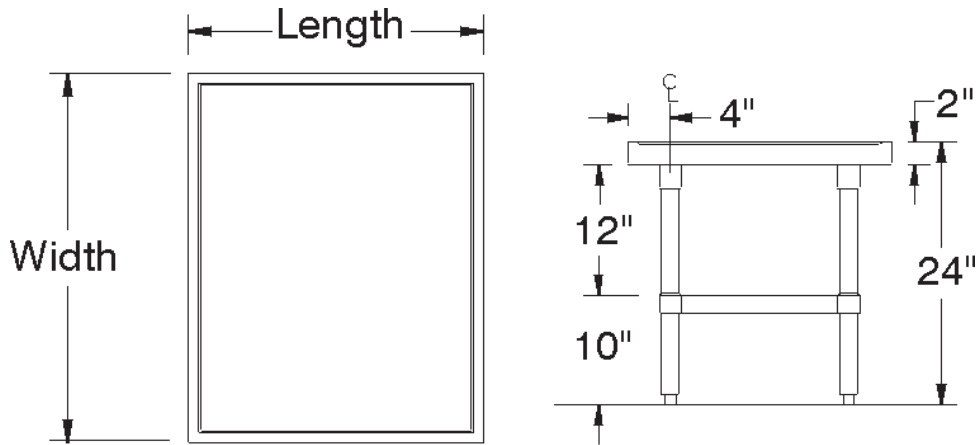

MX Series

1 5/8" \varnothing Hole Accomodates Utensil Rack

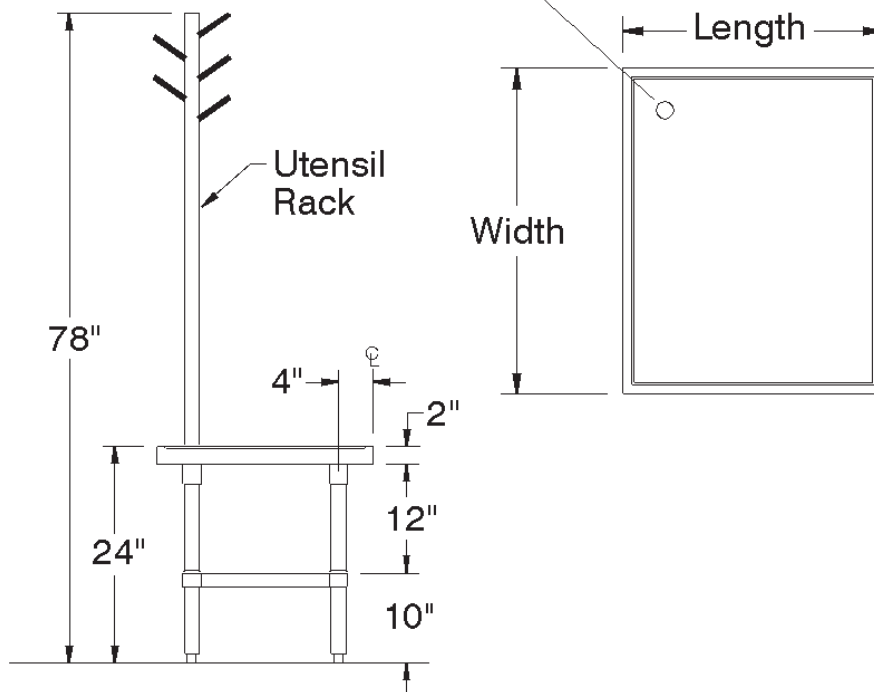

Direct Phone & Service: (516) 527-3309 • (888) 443-7014 • info@unisourcefoodequipment.com • unisourcefoodequipment.com
170 Wilbur Place, Suite 300, Bohemia, New York, 11716