

50 Percent
Energy Savings

unisource
FOOD EQUIPMENT SYSTEMS
Follow the Leader™

No Assembly Needed!
Fits Through
Standard Door

UNISOURCE ULTRA-MAX HIGH EFFICIENCY COMPACT BAGEL HEARTH OVEN

THE SMALLEST BAGEL OVEN IN THE INDUSTRY!

Unisource Energy Saving Concept:

The **Unisource Bagel hearth Oven** oven is a static oven which means there are no fans to dry out your bagels. The most important characteristic of this oven is the **Unique Heating System**.

Heat is supplied by a Dense Network of **Patented Closed Vapor Tubes** in which the hot steam circulates. The baking chambers on each deck are wrapped by these vapor tubes in the around the entire deck. each vapor steam tube is **individually tested** and certified at our factory. This unique concept of heating vapor steam tubes provides our customers with **low, low energy consumption, quick temperature recovery** and the **perfect uniform bake every time!** This oven is so energy Efficient, after 12 hours of the oven turned off, it still holds 250°!

CONSTRUCTION:

High quality stainless steel is used on the entire outside & inside of the oven for easy cleaning and very attractive look.

STEAM SYSTEM FOR BAGELS:

Easy Baking Chamber has its own powerful **Self-Contained High Capacity Steam System** that is ready on demand for **Artisan Breads, Bagels and Rolls**. No kettle needed!

Features:

- Uses 18" x 26" American Pans and Bagel Boards!
- Oven doors fold down for easy cleaning and loading
- CE & UL Compliant
- Genuine Vapor Tube Technology for brick Oven quality artisan baking
- The smallest foot print in the industry. Needs no assembly. Fits through standard door.
- Available in a variety of sizes as small as 45" x 35"
- Individual, self-contained high capacity steam for bagel shine & crispy outside
- Save 50% on energy with new gas Vapor Tube Technology
- Natural gas, propane or oil fired burners
- High efficiency Burners and other components are front mounted, for easy access in tight spaces for secure "0" clearance
- All stainless steel construction with vapor hood included
- Oven comes fully assembled. No installation required
- Halogen lamps on each deck
- Includes stand and hood
- Full doors for easy viewing
- One year parts/labor warranty
- 24/7 nationwide service



EXCLUSIVE DESIGN!!
Front Doors Swing Down for Easy
Cleaning & Bagel Board Loading.

BE CAREFUL OF IMITATIONS!
Other competitor's oven doors open up into the oven, not allowing access to the doors to clean. Their doors require tools to remove and can break or shatter!

ENERGY SAVING FEATURES AND GENUINE HEARTH BAKING

The secret is the Vapor Tubes that deliver heat evenly throughout the oven, with **no moving parts** necessary to distribute the heat. This provides consistent **quality front to back, side to side and deck to deck**.

Please Note: Customer is responsible for all connections to oven to local codes

Direct Phone & Service: (516) 527-3309 • (888) 443-7014 • info@unisourcefoodequipment.com • unisourcefoodequipment.com
170 Wilbur Place, Suite 300, Bohemia, New York, 11716



UNISOURCE ULTRA-MAX HIGH EFFICIENCY COMPACT BAGEL HEARTH OVEN

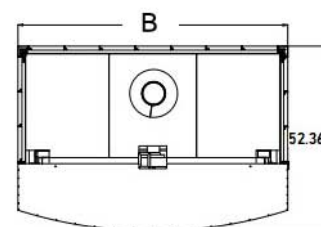
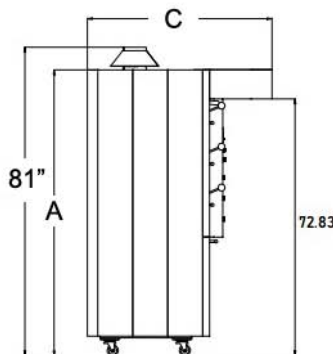
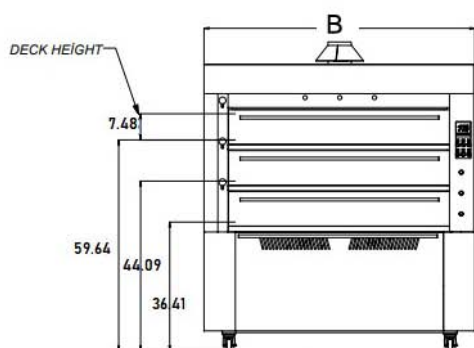

UNIQUE DESIGN!

Fits Standard American 18" X 26" Pans & Bagel Boards For Baking, Bagels, Pastries, Pies, Cookies, Etc...

1. Water Pipe Connection - 1/2"
2. Drain of Steam Generator - 1/2"
3. Gas Pipe Connection - 3/4"
4. Single Phase Connection
Electrical 208/60/1 Phase 20 amps
5. 7" Combustion Stack Vent

BAGEL TROUGH

- 3 Drains
- Seed Keeper To Prevent Drain From Clogging
- Lower Storage Shelf



	BBT45	BBT65	BBT84
Height	40"	40"	40"
Width	45"	65"	84"
Length	20.5"	20.5"	20.5"

95% of parts can be purchased by local parts store.

Model	Pans	Pan Size	M ² SQM	Weight	Heating Power	(A) Height	(B) Width	(C) Depth	(D) Vent
XBR-3	3	66 x 46 cm 26" x 18"	1,21	2300 lbs.	51,000 BTUs	77"	45"	35"	81"
XBR-6	6	66 x 46 cm 26" x 18"	2,21	2500 lbs.	95,000 BTUs	77"	65"	35"	81"
XBR-9	9	66 x 46 cm 26" x 18"	3, 62	2700 lbs.	135,000 BTUs	77"	76"	35"	81"
XBR-12	12	66 x 46 cm 26" x 18"	4, 75	3000 lbs.	160,000 BTUs	77"	96"	35"	81"

ALL OVENS 3 DECKS HEIGHT

Direct Phone & Service: (516) 527-3309 • (888) 443-7014 • info@unisourcefoodequipment.com • unisourcefoodequipment.com
170 Wilbur Place, Suite 300, Bohemia, New York, 11716