



HALSTON DESIGNER SERIES

Countertop refrigerated display case



PRODUCT SPECIFICATION

Model	Doors	Capacity (cu.ft)	Shelves	Cabinet Dimensions (Inches / mm)			HP	Voltage	Amps	TEMP	Net Weight (lbs. / kg)
				L	D	H					
ST530A	2	3.95	2	34 3/5" 868	22 2/5" 568	27" 686	1/3	110V/60Hz	2.80	36°F ~43°F	145 66



STANDARD FEATURES

- This bakery display case features bright, cool LED lighting that is designed to show off your chilled baked goods!
With a proper display, your bakery items can merchandise themselves and increase impulse sales.
- The case also has two chrome plated wire interior shelves that you can adjust depending on the items you want to display. In total, this model has a capacity of 3.95 cu. ft.
- The curved front glass provides an unobstructed view of your food while the side glass panels and the rear glass access doors ensure that customers can see the case's contents from any angle.
- A specialized air outlet design circulates air against the curved glass front to reduce the build-up of condensation. Without condensation to get in the way, your customers will always have clear visibility to your tempting desserts!
- This model uses eco-friendly R-290 refrigerant to keep the interior temperatures at safe levels between 36-43 degrees Fahrenheit. This specialized refrigerant has an ozone depletion potential (ODP) of 0 and a global warming potential (GWP) of 3, making it an environmentally-responsible choice for your business. It has a 1/3 hp compressor and requires a 110V electrical connection for operation.
- ETL approved (conforms to UL-471&NSF-7)
- DOE 2017, Energy efficient compliant

Plan view

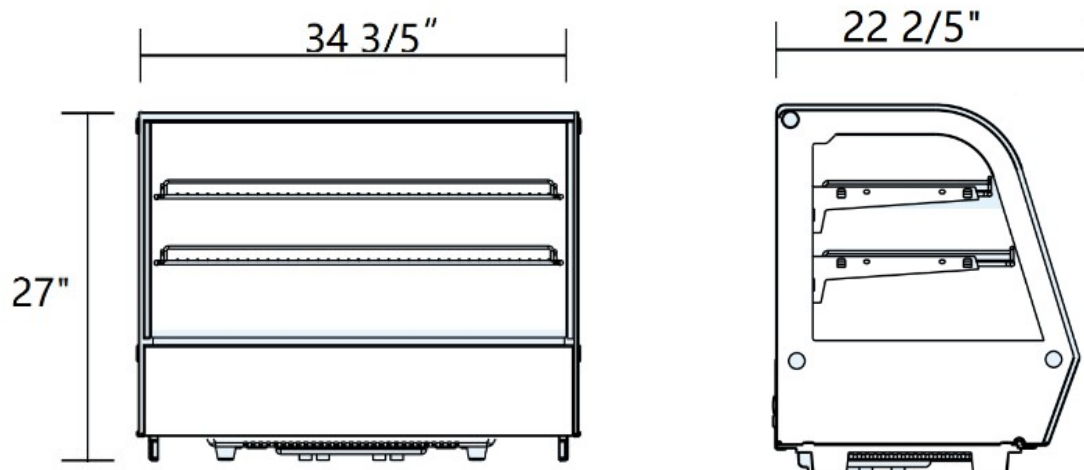

Direct Phone & Services: (516) 527-3309 . (888) 443-7014. info@unisourcefoodequipment.com . unisourcefoodequipment.com

170 Wilbur Place, Suite 300, Bohemia, New York, 11716