



HALSTON DESIGNER SERIES

“Z940” DISPLAY CASES WITH FLAT FRONT REFRIGERATED & NON-REFRIGERATED STYLES



STANDARD DISPLAY
UNI-Z940A/ UNI-Z940A-NR



LARGE DISPLAY
UNI-Z940W/ UNI-Z940W-NR

Standard Features:

- Three Adjustable Lighted Shelves
- Two Full End Panels With Mirror Interior
- Clear Glass Rear Sliding Doors
- Led Top Light And Shelf Lights & 8 Ft. Cord
- Flat Single Pane Lift-Up or Fixed Front Glass
- Adjustable Legs With Casters
- Movable Shelves & Shelf Brackets

Additional Features For Refrigeration Units

- Fan Cooling Refrigeration System
- High Quality Digital Temperature Controller
- Sliding Out Condensing Unit For Easy Maintenance
- Automatic Defrost System
- CFC-Free R-134A Refrigerant
- Range Of Temperature: 41° F.

Model	Doors	Capacity		Shelves	Cabinet Dimensions			HP	Voltage	Amps	Wt. (lbs)
					L	D	H				
REFRIGERATED DISPLAYS											
UNI-Z940A UNI-Z940A-NLG*	2	18"x12"	18"x9"	3	47 1/4"	37 1/4"	54"	1/3	110V/60Hz	6.50	606
		11 Pcs (3x3+2)	14 Pcs (3x4+2)								
UNI-Z940W UNI-Z940W-NLG*	2	2 1/2 Full Pans/Per Shelf		3	50 3/8"	42"	54"	1/3	110V/60Hz	6.50	639
NON-REFRIGERATED DISPLAYS											
UNI-Z940A-NR UNI-Z940A-NR-NLG*	2	18"x12"	18"x9"	3	47 1/4"	37 1/4"	54"	-	110V/60Hz	.35	586
		11 Pcs (3x3+2)	14 Pcs (3x4+2)								
UNI-Z940W-NR UNI-Z940W-NR-NLG*	2	2 1/2 Full Pans/Per Shelf		3	50 3/8"	42"	54"	-	110V/60Hz	.35	619

* -NLG Series has non-lifting front glass



Bakery Aid™

Innovation



HALSTON DESIGNER SERIES

“Z940” DISPLAY CASES WITH FLAT FRONT

REFRIGERATED & NON-REFRIGERATED STYLES

Optional 24 Hour Monitoring System

Receive Wifi alerts detected from the display case! Be aware before its to late and losing perishable foods.

- Model: UNI-CDP-210**
- 3 temperature Sensors
 - 8.5" x 4.7" x 4.1"
 - 115V/60Hz.



STANDARD DISPLAY UNI-Z940A/UNI-Z940A-NLG/UNI-Z940A-NR/UNI-Z940A-NR-NLG

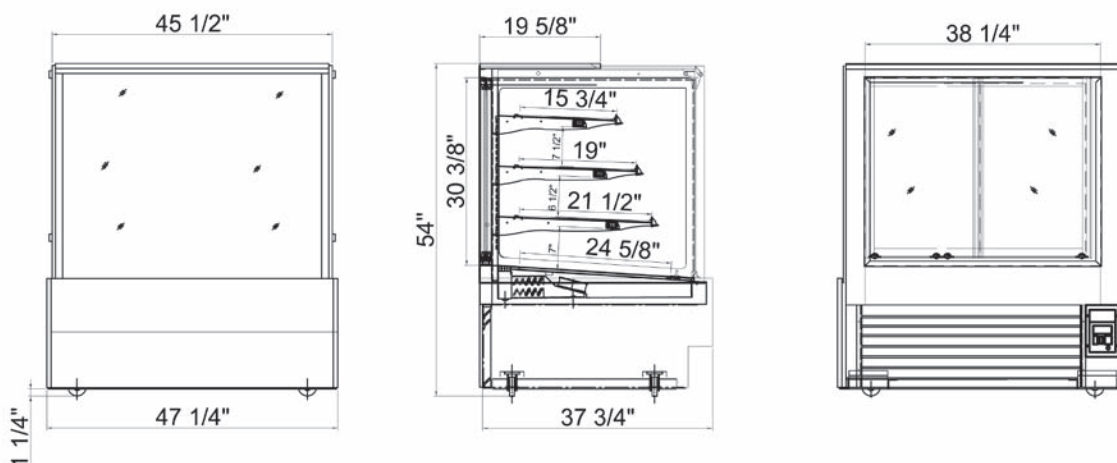

LARGE DISPLAY UNI-Z940W/UNI-Z940W-NLG/UNI-Z940W-NR/UNI-Z940W-NR-NLG

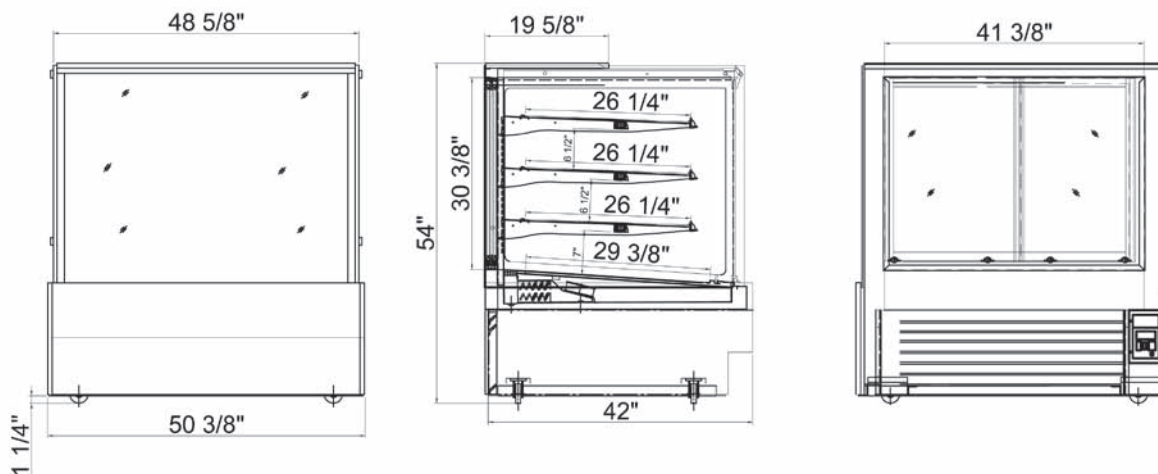

Direct Phone & Service: (516) 527-3309 • (888) 443-7014 • info@unisourcefoodequipment.com • unisourcefoodequipment.com
 170 Wilbur Place, Suite 300, Bohemia, New York, 11716

BAKERY AID INNOVATION™ is constantly engaged in a program of improving our products. Therefore, we reserve the right to change specifications without prior notice.
 © BAKERY AID INNOVATION™ is a Trademark of Unisource Food Equipment, JUNE 2020