



HALSTON DESIGNER SERIES

Double glass door refrigerated merchandiser display case



PRODUCT SPECIFICATION

Model	Doors	Capacity (cu.ft)	Shelves	Cabinet Dimensions (Inches / mm)			HP	Voltage	Amps	Cord Length (ft.)	Net Weight (lbs. / kg)
				L	D	H					
UNI-GDM-36F	2	27.5	8	35.4" 900	27.8" 705	78.9" 2000	2/3	110V/60Hz	6.80	6	408 185
UNI-GDM-48F	2	39	8	48" 1220	31.5" 800	84" 2135	2/3		7.50		454 206
UNI-GDM-53F	2	48	8	53" 1350	31.5" 800	84" 2135	1		8.60		540 245



STANDARD FEATURES

- Heavy duty construction includes white coated aluminum or stainless steel walls and black powder coated steel for exterior
- *Refrigeration system is optimized to function between $-8^{\circ}F \sim 0^{\circ}F$*
- *High quality digital temperature controller*
- *With caster and adjustable legs*
- *Sliding out condensing unit*
- *LED light inside top and two sides*
- *Triple glazed safety glass with heated film inside*
- *Automatic defrost system*
- *R290 Refrigerant, O-zone friendly*
- *ETL approved (conforms to UL-471&NSF-7)*
- *DOE 2017, Energy efficient compliant*

Plan view

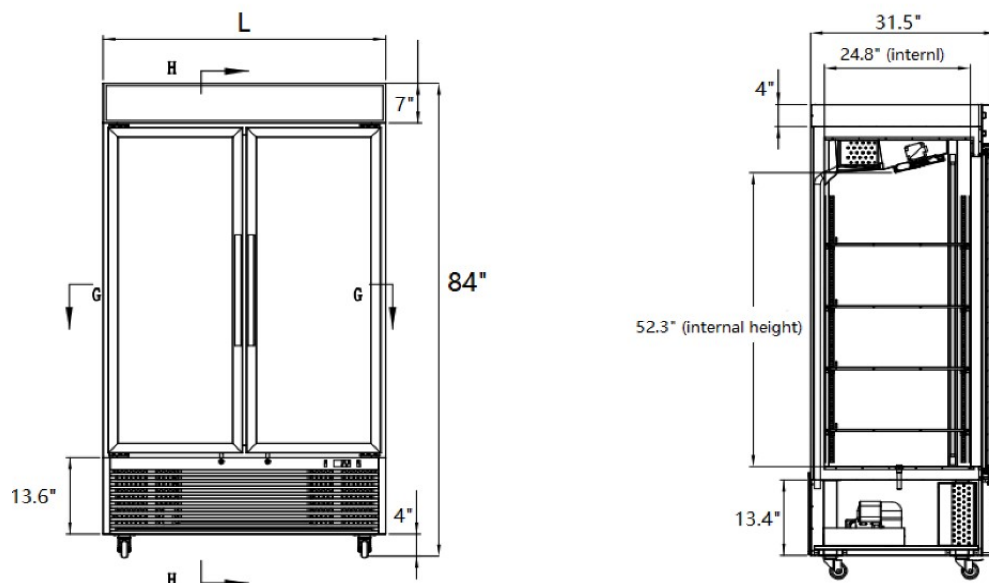

Direct Phone & Services: (516) 527-3309 . (888) 443-7014. info@unisourcefoodequipment.com . unisourcefoodequipment.com

170 Wilbur Place, Suite 300, Bohemia, New York, 11716