



HALSTON DESIGNER SERIES

Straight Glass Deli Case



PRODUCT SPECIFICATION

Model	Doors	Capacity (cu.ft)	Shelves	Cabinet Dimensions (Inches / mm)			HP	Voltage	Amps	Cord Length (ft.)	Net Weight (lbs. / kg)
				L	D	H					
UNI-DZ1200S	2	18	2	47.2" 1200	32.5" 825	45.2" 1148	1/3	110V/60Hz	4.20	6	408 185
UNI-DZ1500S	2	22	2	59" 1500	32.5" 825	45.2" 1148	1/2	110V/60Hz	5.50	6	462 210
UNI-DZ1800S	2	26	2	70.8" 1800	32.5" 825	45.2" 1148	1/2	110V/60Hz	6.80	6	550 250
UNI-DZ2000S	2	30	2	78.75" 2000	32.5" 825	45.2" 1148	1/2	110V/60Hz	7.20	6	630 286



In Accordance with
AHRI Std 1200

DOE 2017
Energy Efficiency
Compliant

STANDARD FEATURES

- Refrigeration system is optimized to function between 33~ 41 °F
- Exterior tempered glass finish
- With caster and adjustable legs
- Movable shelf
- Gravity coil refrigeration system
- Sliding out condensing unit
- LED light inside top
- High quality digital temperature controller
- Double glazed safety glass with Low-E film inside
- Automatic defrost system
- R290 Refrigerant, O-zone friendly
- ETL approved (conforms to UL-471&NSF-7)
- DOE 2017, Energy efficient compliant

Plan view

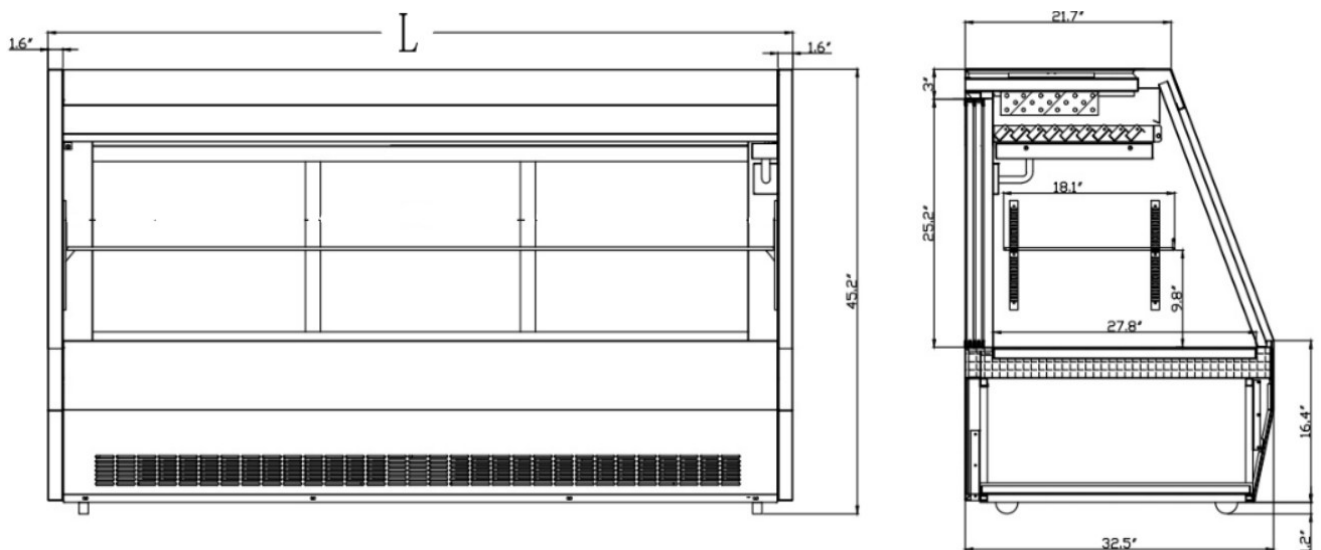

Direct Phone & Services: (516) 527-3309 . (888) 443-7014. info@unisourcefoodequipment.com . unisourcefoodequipment.com

170 Wilbur Place, Suite 300, Bohemia, New York, 11716