



HALSTON DESIGNER SERIES REFRIGERATED COMBO DISPLAY CASES

Standard Features:

- Four Adjustable Shelves With LED Lights.
- Two Cut-Away End Panels With Mirror Inside Lower Section.
- Two Clear Glass Rear Sliding Doors.
- Top Curved Double Pane Glass With Lift-Up or Fixed Front Glass. Includes With Heater.
- Adjustable Legs With Casters.
- Four Ft. Power Cord.

Additional Features For Refrigeration Units

- Fan Cooling Refrigeration System.
- High Quality Digital Temperature Controller.
- Condensate Pan With Drawer System.
- Automatic Defrost System.
- CFC-Free R-290 Refrigerant.
- Range Of Temperature: 36° - 40° F.



UNI-DS-900 Shown

Model	Doors	Capacity (Cu. Ft)	Shelves	Cabinet Dimensions			HP	Voltage	Amps	Wt. (lbs)
				L	D	H				
REFRIGERATED DISPLAYS										
UNI-DS-900 UNI-DS-900-NLG*	2	17.6	2	35.8"	33.7"	57.5"	1/3	110V/60Hz	6.20	518
UNI-DS-1200 UNI-DS-1200-NLG*	2	22.9	2	47.6"	33.7"	57.5"	1/2	110V/60Hz	7.0	617
UNI-DS-1500 UNI-DS-1500-NLG*	2	26.5	2	59.5"	33.7"	57.5"	1/2	110V/60Hz	7.0	732

* -NLG Series has non-lifting front glass



Bakery Aid™

Innovation



HALSTON DESIGNER SERIES REFRIGERATED COMBO DISPLAY CASES

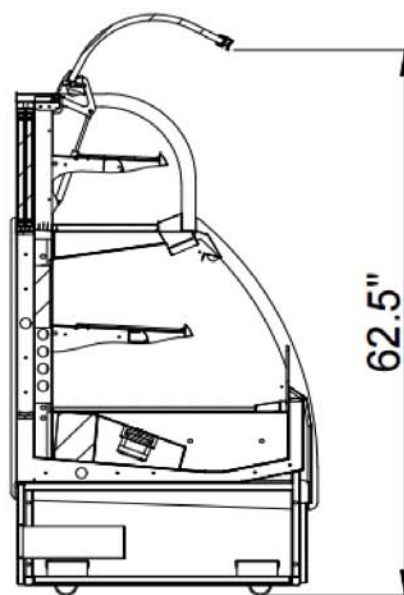
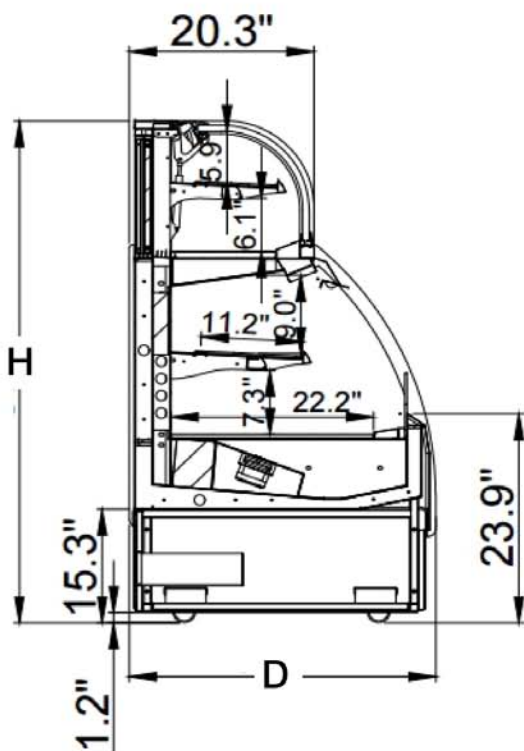
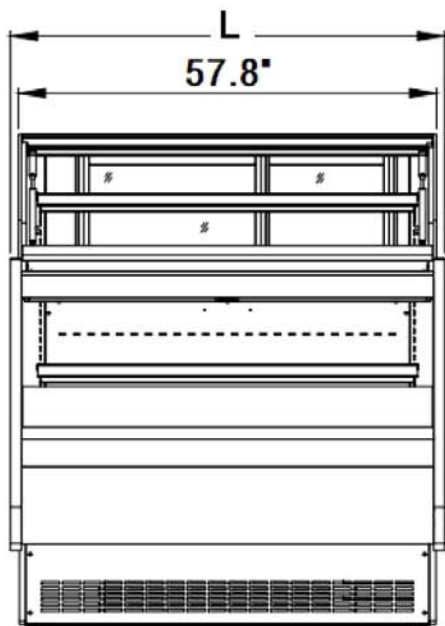

Unit Shown With Optional Lift Glass

Direct Phone & Service: (516) 527-3309 • (888) 443-7014 • info@unisourcefoodequipment.com • unisourcefoodequipment.com
170 Wilbur Place, Suite 300, Bohemia, New York, 11716

BAKERY AID INNOVATION™ is constantly engaged in a program of improving our products. Therefore, we reserve the right to change specifications without prior notice.
© BAKERY AID INNOVATION™ is a Trademark of Unisource Food Equipment, JUNE 2020