



Follow the Leader™

## Bakery Encore Series - Non-Refrigerated Service Cases



- Curved single pane, lift-up front glass
- Flat front panel
- LED top & shelf lights
- One year parts & labor warranty
- Shelving removable and adjustable on 1" centers



FEATURES	STANDARD	OPTIONS
EXTERIOR COLOR	<input type="checkbox"/> Laminated (Non-Premium) Confirm Pattern/Grain Direction	<input type="checkbox"/> Laminated (Premium) Confirm Pattern/Grain Direction <input type="checkbox"/> Stainless Steel (Includes Rear Of Case)
INTERIOR COLOR	<input type="checkbox"/> Black	<input type="checkbox"/> Stainless Steel <input type="checkbox"/> White
REAR EXTERIOR COLOR	<input type="checkbox"/> Painted - White	<input type="checkbox"/> Painted - Black <input type="checkbox"/> Stainless Steel (W/Stainless Ext. Only)
TRIM COLOR	<input type="checkbox"/> Black	<input type="checkbox"/> Silver
BASE	<input type="checkbox"/> Levelers	<input type="checkbox"/> 6" H Legs ❖ Casters (N/A With Remote)
END PANEL LEFT	<input type="checkbox"/> Full End Panel W/Mirror Interior	<input type="checkbox"/> Case To Case Glass End <input type="checkbox"/> Cutaway With Glass <input type="checkbox"/> No End Panel (For Same Case To Case Connect)
END PANEL RIGHT	<input type="checkbox"/> Full End Panel W/Mirror Interior	<input type="checkbox"/> Case To Case Glass End <input type="checkbox"/> Cutaway With Glass <input type="checkbox"/> No End Panel (For Same Case To Case Connect)
UPPER REAR	<input type="checkbox"/> Clear Glass Rear Sliding Doors W/O Lock	<input type="checkbox"/> Reflective Glass Rear Sliding Doors W/O Lock
SHELVING	<input type="checkbox"/> Wire Rack Shelves (3)	<input type="checkbox"/> Clear Glass Shelves, Lighted (Led)
ELECTRICAL CONNECT	<input type="checkbox"/> 12" Straight Blade Power Cord	<input type="checkbox"/> 12" Locking Power Cord <input type="checkbox"/> Electrical Leads (Non-Refrigerated)
MISCELLANEOUS		<input type="checkbox"/> Front Glass Lock <input type="checkbox"/> Rear Door Lock <input type="checkbox"/> Second Year Parts & Labor Warranty

Other Color Choices By WilsonArt® Are Available Upon Request

Direct Phone & Service: (516) 527-3309 • (888) 443-7014 • info@unisourcefoodequipment.com • unisourcefoodequipment.com  
170 Wilbur Place, Suite 300, Bohemia, New York, 11716

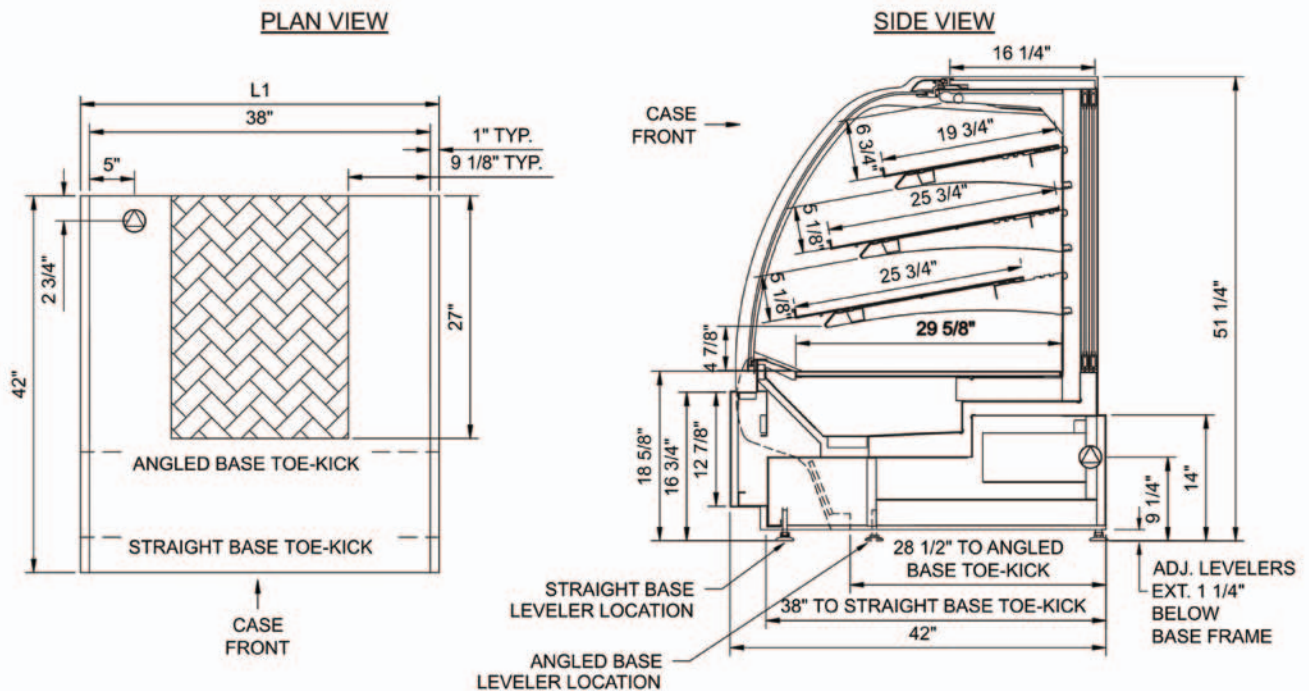

NOTE: ALL DIMENSIONS APPROXIMATE

-  ELECTRICAL JUNCTION BOX (SUPPLIED WITH 6" LEADS OR POWER CORDS)
-  REFRIGERATION LINE CONNECTION
-  SELF-CONTAINED CASE SERVICE ACCESS AREA
-  REMOTE FLOOR SINK & UTILITIES ACCESS AREA
-  DRY CASE SERVICE ACCESS AREA

Model	L	L1	System Circuit Volts		Phase	Freq
HV38	38"	40"	Ambient	Circuit #1	110-120	1 60
HV48	48"	50"	Ambient	Circuit #1	110-120	1 60
HV56	56"	58"	Ambient	Circuit #1	110-120	1 60
HV74	74"	76"	Ambient	Circuit #1	110-120	1 60

Amps	Watts	Wires	NEMA Plug	SST	BTUH	Wt.
0.53	68	2+G	5-15P or L5-15P	N/A	N/A	800 lbs.
0.76	100	2+G	5-15P or L5-15P	N/A	N/A	900 lbs.
0.99	128	2+G	5-15P or L5-15P	N/A	N/A	950 lbs.
1.38	160	2+G	5-15P or L5-15P	N/A	N/A	1000 lbs.



All Models ETL  
Listed to UL 65  
ETL Sanitation to  
NSF 2

**IMPORTANT NOTES:**

- 1) ELECTRICAL NOTE: If GFCI is required, a GFCI breaker MUST be used in lieu of a GFCI receptacle
- 2) 43" Minimum door entry clearance required (Without shipping skid).
- 3) Units are supplied with levelers. They must be adjusted during installation to ensure the unit is level and plumb. Dimensions reflect levelers extended 1 1/4".

Direct Phone & Service: (516) 527-3309 • (888) 443-7014 • info@unisourcefoodequipment.com • unisourcefoodequipment.com  
170 Wilbur Place, Suite 300, Bohemia, New York, 11716